

Grinding & Machining for sealing surfaces

Surface Grinding Machine

CHRIS-MARINE®

CPM

For grinding of sealing surfaces between cylinder head and cylinder liner, and between cylinder liner and engine frame on medium bore diesel engines.



Product features

- Standard operating range diameter 350 - 700 mm
- Easily operated by one man
- For workshops onboard and ashore
- Versatile
- Pneumatically operated
- Optional milling equipment

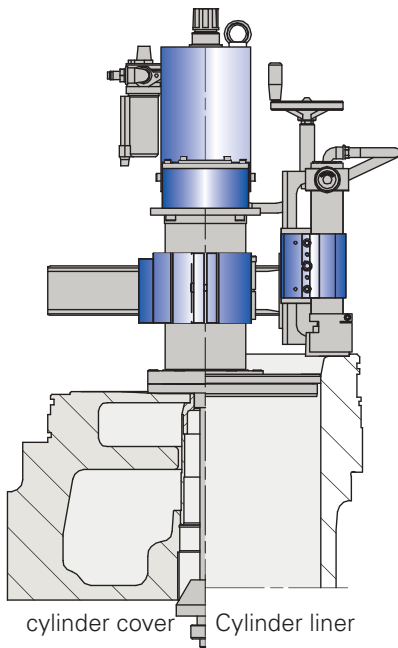

cylinder cover Cylinder liner

Milling

Milling groove in cylinder liner / cylinder cover with high speed carbide tool.

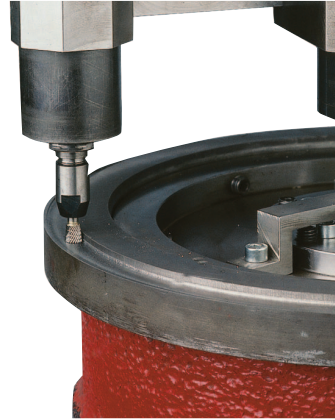
**CPM machine mounted on cylinder cover and cylinder liner**

A wide range of specific mounting adapters is available to fit various grinding applications on all medium 4-stroke engines in the market.

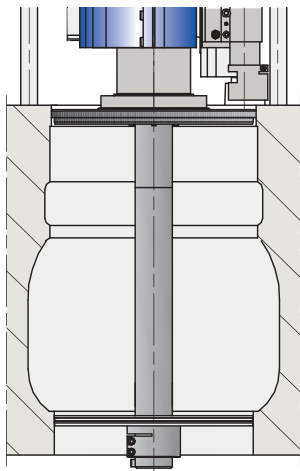
**CPM machine mounted on engine frame**

Standard application for grinding landing surface on engine frame.

CPM machine mounted on cylinder liner with extra accessories for under-up grinding

Frequently used application for eliminating water leakage due to corroded landing surfaces.

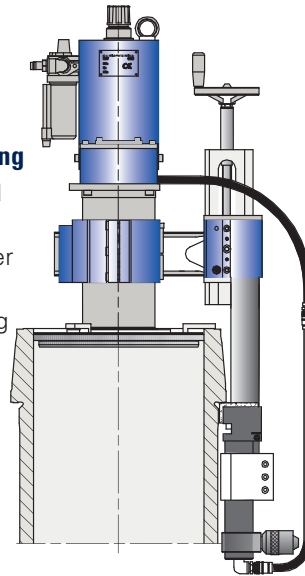
**Chris-Marine Headquarters and Subsidiaries**

CHRIS-MARINE SWEDEN HEADQUARTERS
Tel: +46 - 40 671 2600
info@chris-marine.com

CHRIS-MARINE DENMARK
Tel: +45 - 4498 3833
iop@chris-marine.com

CHRIS-MARINE GERMANY
Tel: +49 4101 5880 0
lemag@chris-marine.com

CHRIS-MARINE SINGAPORE
Tel: +65 - 6268 8611
chris-sm@chris-marine.com.sg

CHRIS-MARINE CHINA
Tel: +86 - 21 6575 9331
info.cn@chris-marine.com

CHRIS-MARINE JAPAN
Tel: +81 - 78 570 5642
info.jp@chris-marine.com

CHRIS-MARINE INDIA
Tel: +91 - 712 224 2719
info.in@chris-marine.com

CHRIS-MARINE ECUADOR
Tel: +593 979 000 379
info.ec@chris-marine.com

CHRIS-MARINE BRAZIL
Tel: +55 21 3349-4349
info.br@chris-marine.com

Contact one of our offices to get in touch with your local agent.

Technical specifications

• Machine capacity	Ø350 - Ø700 mm
• Air pressure	0.6 - 0.9 MPa (6 - 9 bar or 85 - 130 psi)
• Air consumption	1500 l/min
• Air hose connection	16 mm (5/8")
• Weight	Basic machine 95 kg Aligning equipment 5 - 85 kg
• Max dimensions	H: 642 mm